

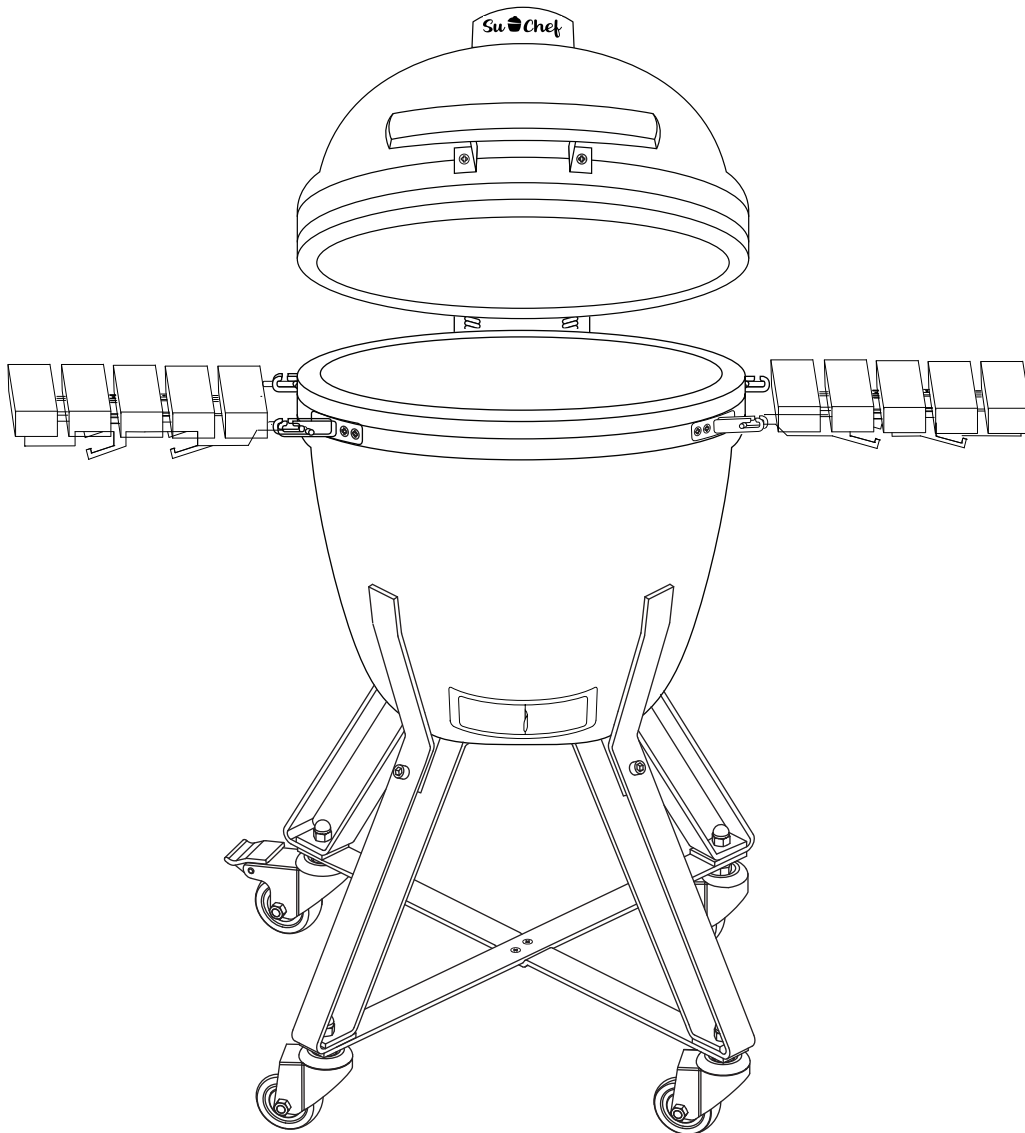

User Instructions - Please keep for future reference

SU CHEF GRANDE CERAMIC GRILL



User Instructions - Please keep for future reference

IMPORTANT – Carefully remove any packaging before use, but retain the safety instructions. These instructions form part of the product.
Please take note of all of the safety warnings listed in these instructions.
Please read these instructions in their entirety and retain them for future reference.
These instructions should be stored with the product.
This product is for domestic use **ONLY** and should not be used commercially or for contract purposes.

Care and safe use guidelines

HIGH TEMPERATURE COOKING GUIDE

- Light the lump charcoal according to the the instructions on page 3.
- Close the lid and fully open the top and bottom vents.
- Monitor the Kamado until it has risen to the desired temperature. See page 4 for a temperature cooking guide.
- Close the top vent half way and continue to check the temperature for a few more minutes.
- You are now ready to use the Kamado for cooking on.
- **IMPORTANT:** When opening the lid at high temperatures it is essential to lift the lid only slightly, allowing air to enter slowly and safely, preventing any backdraft or flare-ups that may cause injury.
- **ALWAYS** follow the **FOOD COOKING INFORMATION** stated on page 4 of this instruction manual.
- **ALWAYS** use heat resistant gloves when handling hot ceramics or cooking surfaces.





FOOD COOKING INFORMATION

- **DO NOT** cook until the fuel has a coating of ash.
- Please read and follow this advice when cooking on your Kamado.
- Always wash your hands before and after handling uncooked meat and before eating.
- Always keep raw meat away from cooked meat and other foods.
- Before cooking ensure grill surfaces and tools are clean and free of old food residues.
- **DO NOT** use the same utensils to handle cooked and uncooked foods.
- Ensure all meat is cooked thoroughly before eating.
- **CAUTION** – eating raw or under cooked meat can cause food poisoning (e.g. bacteria strains such as E.coli).
- To reduce the risk of under cooked meat cut open to ensure it is cooked all the way through.
- **CAUTION** – if the meat has been cooked sufficiently the meat juices should be clear and there should be no traces of pink/red juice or meat colouring.
- Pre-cooking larger pieces of meat and joints is recommended before finally cooking on your grill.
- After cooking on your Kamado always clean the grill cooking surfaces and utensils.

REFUELLING

- With the vents closed, the Kamado stays at a high temperature for several hours. If you require a longer cooking time (e.g when roasting a whole joint or slow smoking), it may be necessary to add more charcoal. Just add some additional charcoal and continue as above.

COOKING TEMPERATURE GUIDE

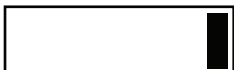
Slow cook / Smoke (110°C-135°C)		Top vent	Bottom vent
Beef Brisket	2 Hrs per lb.		
Pulled Pork	2 Hrs per lb.		
Whole Chicken	3-4 Hr.		
Ribs	3-5 Hrs.		
Roasts	9+ Hrs.		
Grill / Roast (160°C-180°C)		Top vent	Bottom vent
Fish	15-20 Min.		
Pork Tenderloin	15-30 Min.		
Chicken Pieces	30-45 Min.		
Whole Chicken	1-1.5 Hrs.		
Leg of lamb	3-4 Hrs.		
Turkey	2-4 Hrs.		
Ham	2-5 Hrs.		
Sear (260°C-370°C)		Top vent	Bottom vent
Steak	5-8 Min.		
Pork Chops	6-10 Min.		
Burgers	6-10 Min.		
Sausages	6-10 Min.		

Open  Closed 

Parts list

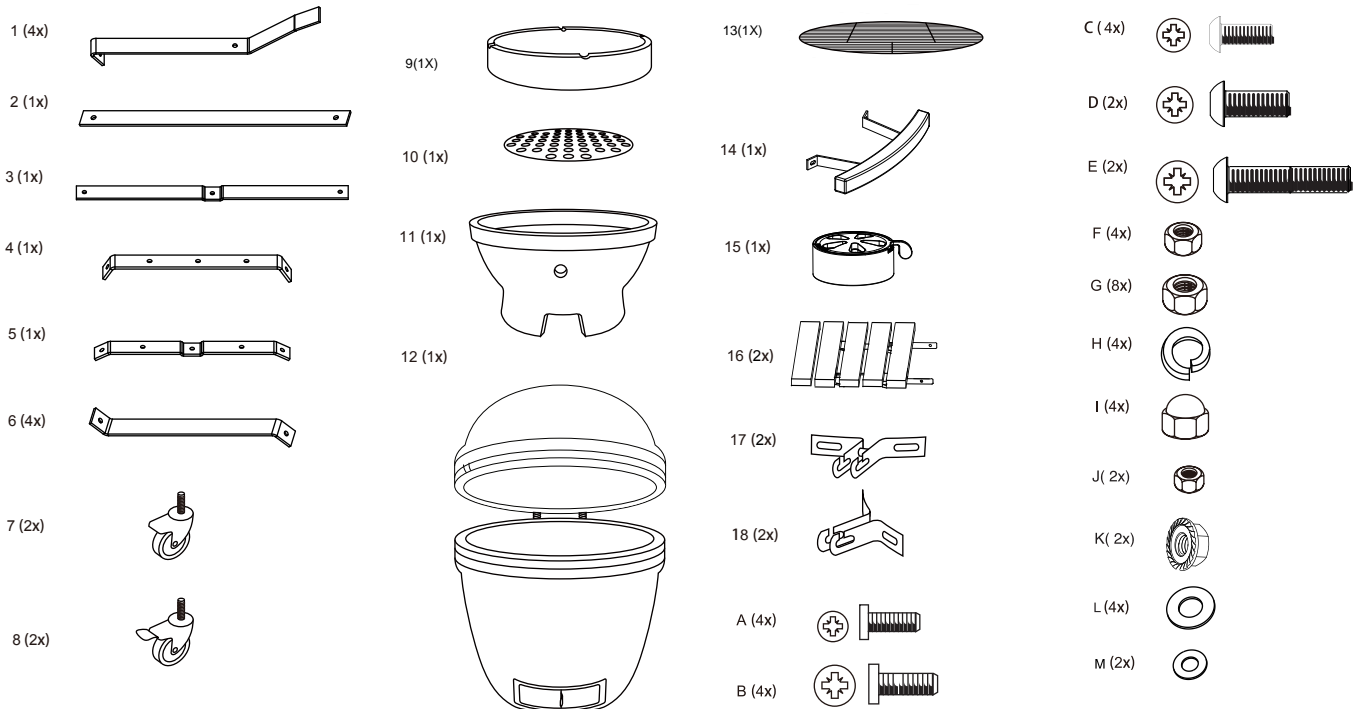

Prior to assembly, read the instructions carefully. Check all parts against the parts list. Carry out assembly on a soft surface to avoid scratching the paint. Please retain this information for future reference. For ease of assembly only loosely tighten bolts and then tighten fully when assembly is complete.

WARNING - DO NOT over tighten bolts; only tighten with moderate pressure to avoid damaging the bolts or components of the Kamado Grill.

Assembly instructions

IMPORTANT - Remove any packaging before use, but retain the safety instructions and store them with this product. Ensure that the lid is closed prior to assembly.

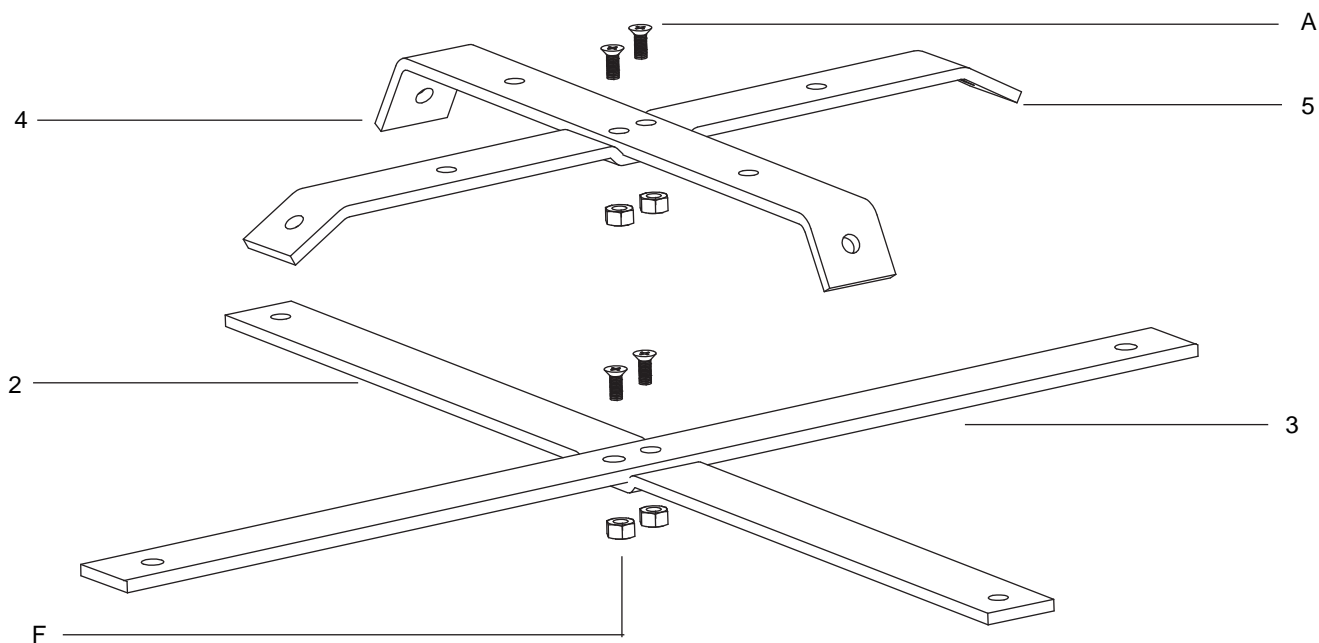

STEP 1 - Position the parts on a flat surface that will not scratch the finish of the nest components, paying close attention to the joint overlap in illustration the 2pcs Upper cross brace(4&5) and 2pcs Lower cross brace(2&3). Using the given hardware and hand tighten the braces with screw A + nut F.

Assembly instructions

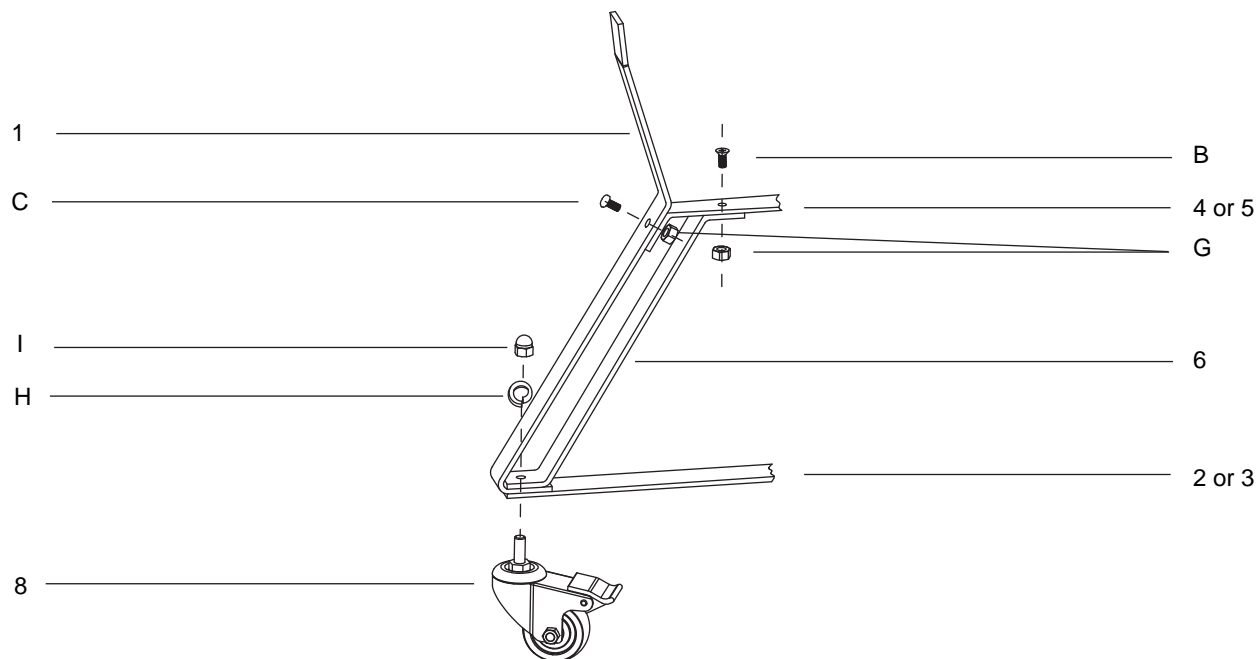

STEP 2 - (Joining the two halves assembled in step 1) Stand the section 1 upright, and place the upper cross braces (4&5) close to section 1. Inserting truss head screw C through the hole of section 1 and section 4&5 and install G nut and tighten securely.

STEP 3 - (Installing the lower cross braces and casters) Place the assembled lower cross braces (2&3) under section 1, Stand the section 6 upright to make it close to section 1 and section 4&5. Inserting screw B through section 4&5 and section 6, install G nut and tighten securely. Next insert the threaded caster stem through the hole in the end of the lower cross brace then through the riser and finally the riser brace. Install (H) flat washer and (I) nut, repeat this at the remaining (8) caster locations and securely tighten.

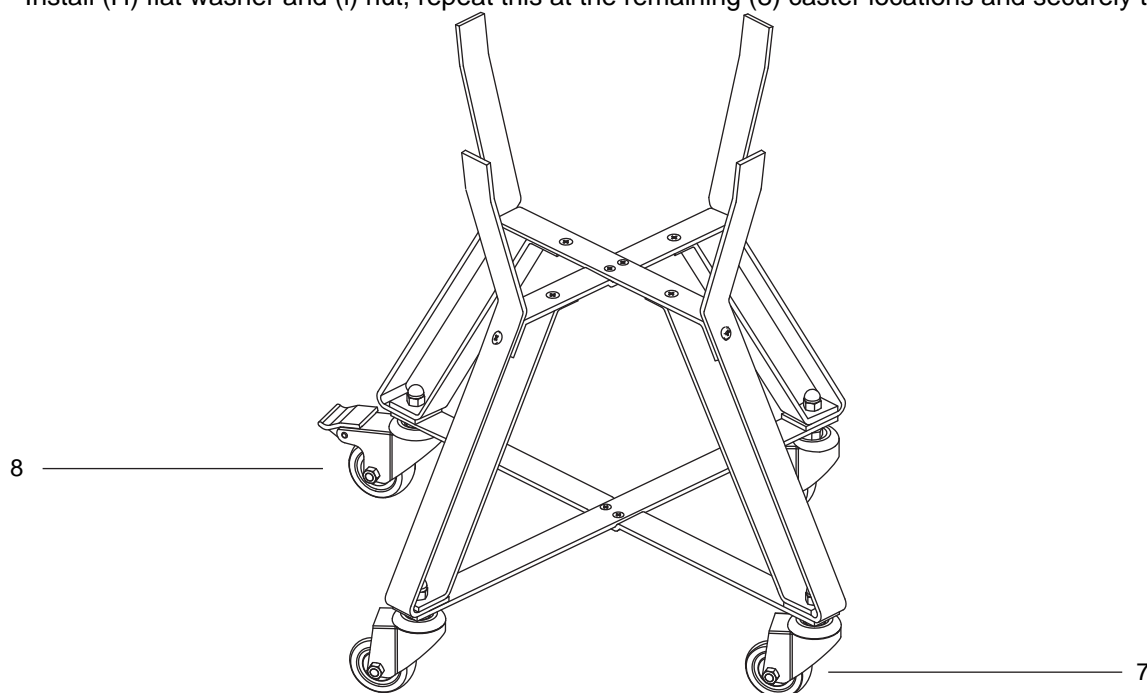

STEP 4 - As picture, put wheels 7 in front, and wheels with brake at the back.

STEP 5 - To place the Kamado on the cart first remove all of the items that are inside of the grill to make lifting easier.

STEP 6 - Use a minimum of two people when lifting the Kamado onto the cart. Place one of your hands in the bottom vent of the Kamado and the other under the grill. Lifting by the hinge or the side tables could result in injury and damage to the product.

STEP 7 - Position the nest upright on a flat level surface with the help of an assistant you can now place the kamado into the nest. Position the kamado so the vent door is accessible between two of the risers and gently push downward on the kamado to seat it in the nest.

Assembly instructions

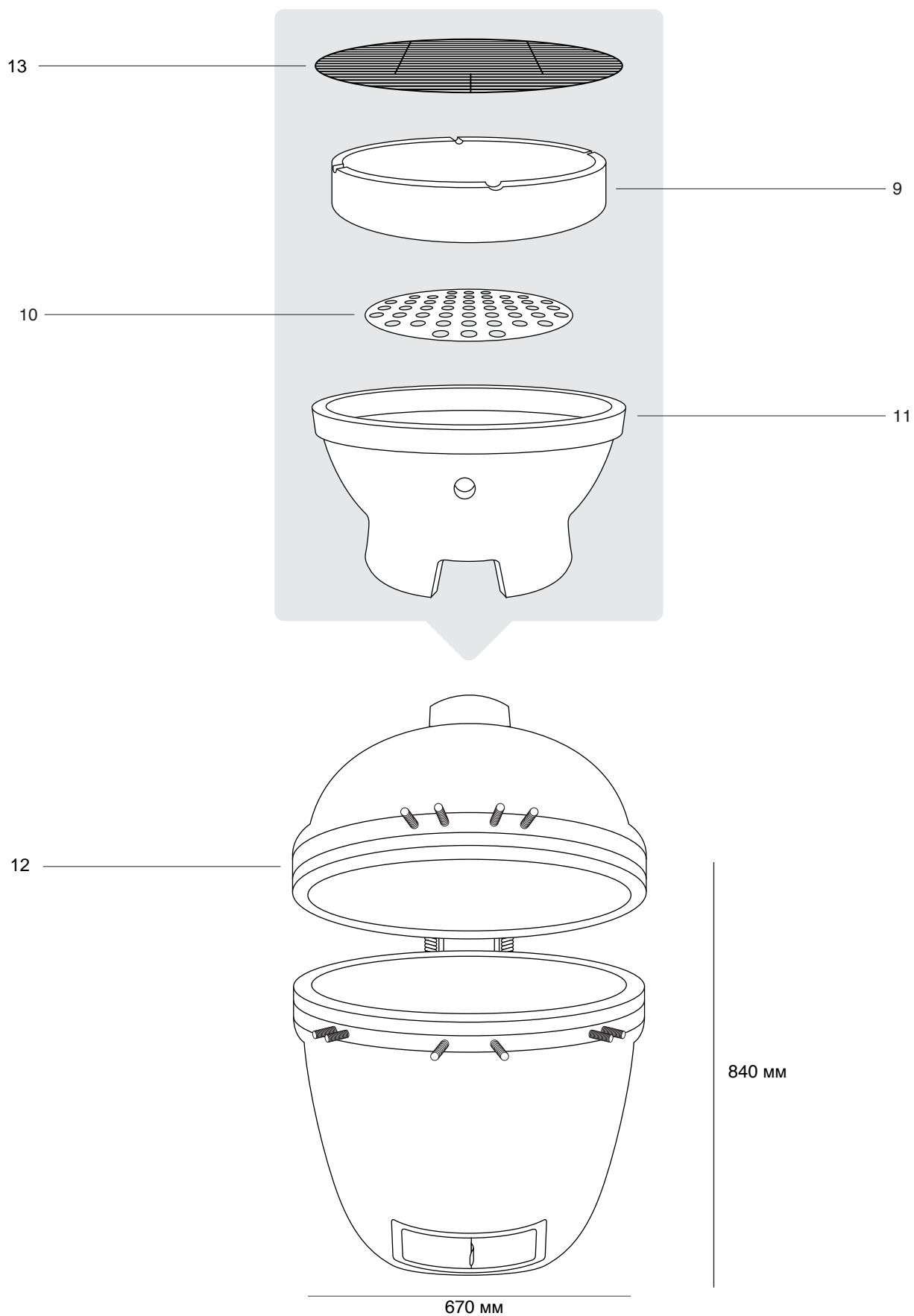

STEP 8 - When the grill is securely placed on the cart add the firebox (11), charcoal plate (10), upper ring (9) and cooking grid (18) inside of the Kamado Grill as displayed in the assembly diagram.

STEP 9 - Press down on the castor levers (8) to lock the castor wheels to ensure the Kamado can not move when in use.

Assembly instructions

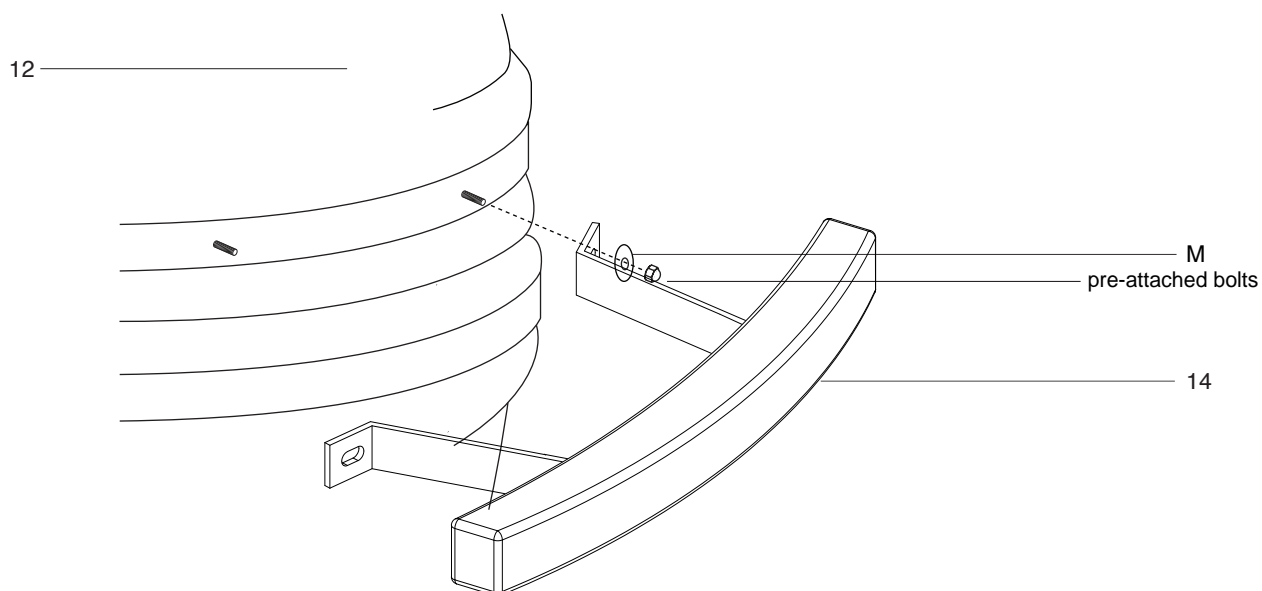

STEP 10 - Attach the lid handle (14) to the ceramic body (12), use the 2x pre-attached bolts with their corresponding washers, locking washers, and nuts per bracket.

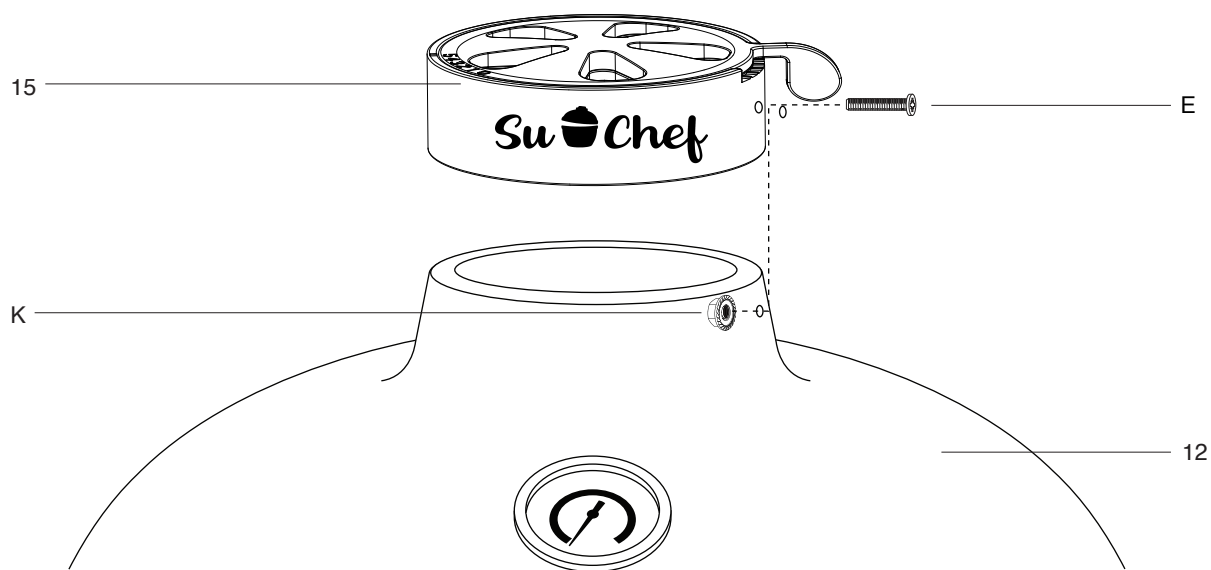

STEP 13 - To attach the top vent (15) to the Kamado Grill (12) place it on top and align both the bolt holes. Secure using 2x bolts (K) and nuts (E). Ensure that the top vent bolt is on the left hand side when assembling it.

Assembly instructions

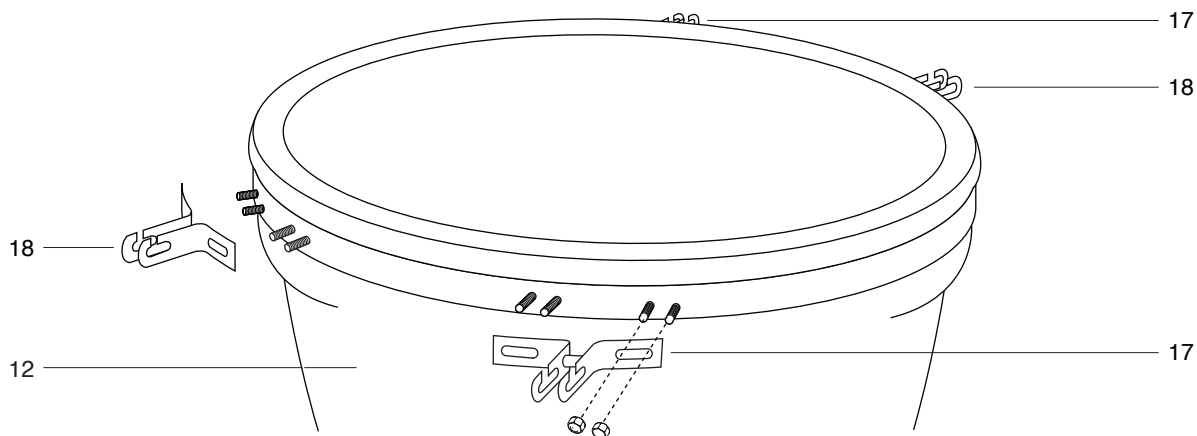

STEP 14 – Attach the 2x table brackets (18) to the Kamado Grill (12) using the 4x pre-attached bolts and dome headed nuts per bracket. Please note the position shown in the above diagram

STEP 15 – Attach the 2x table brackets (17) to the Kamado Grill (12) using the 4x pre-attached bolts and dome headed nuts per bracket. Please note the position shown in the above diagram.

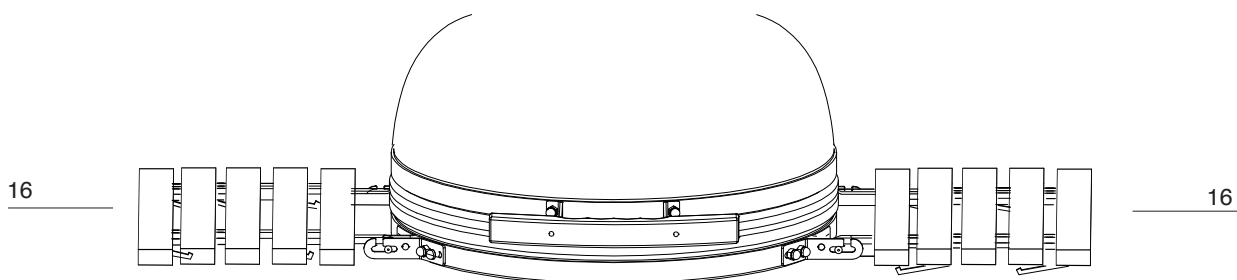

STEP 16 - Insert the 2x table hinge into each of the table brackets (17 & 18).

The Kamado Grill is now ready to use but please ensure that you have read the curing instructions thoroughly prior to use.